

## 3016 - 4001

Features: General purpose. Low profile, dirt exit hole. No seals in 3016 and 3025 units.

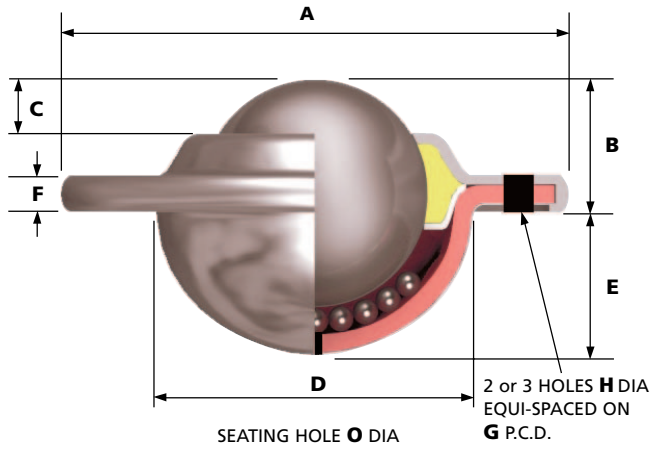

Ball unit Ref. No's 1022 and 1035 with solid steel inner ring (SI) option illustrated with no seal for improved protection from shock loading.

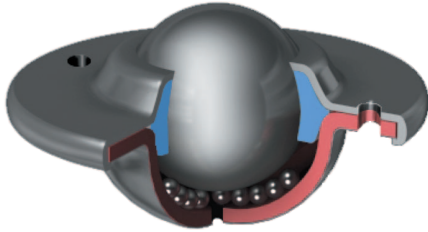

## 1502

Features: Low profile, high load capacity. Plastic knife edge seal on load ball. Dirt exit hole. Requires 5mm radius on fixing hole. See 'R'.

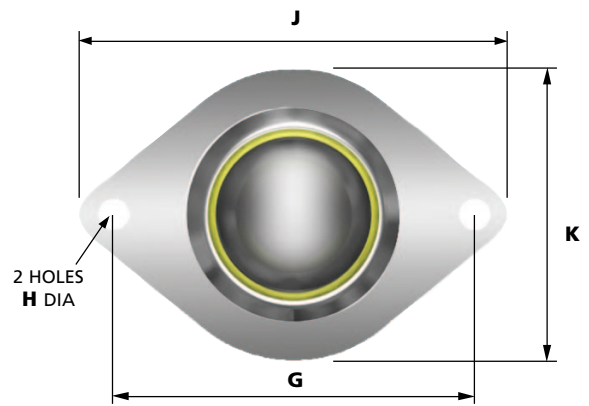
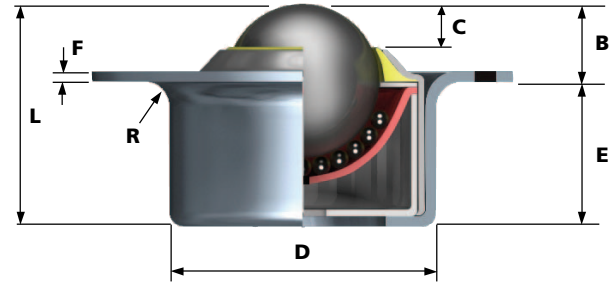

## 1010 / 1030

Features: Press ball unit into hole to fix, prise out to remove. Units can either be fixed or replaced quickly. Low profile, dirt exit hole.

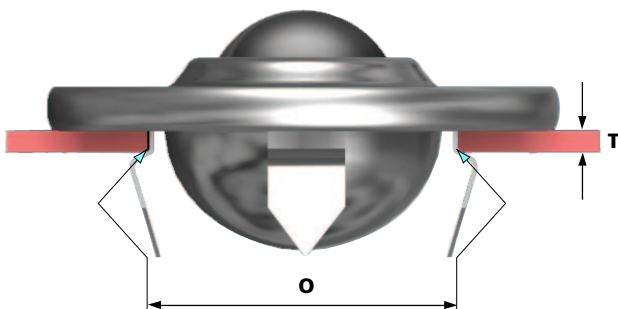
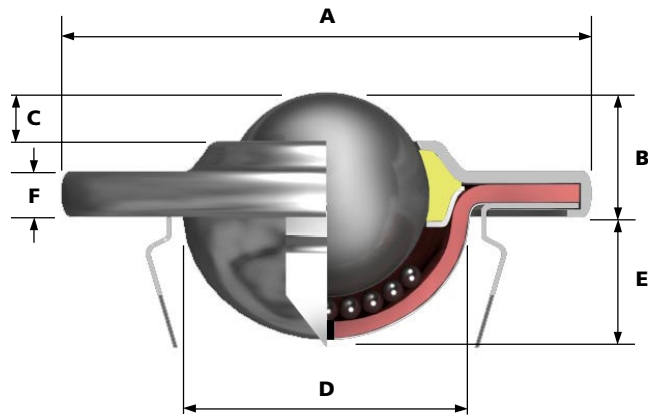

## 2002 XTRA - TUF

Features: Heavy duty construction, designed for arduous and dirty conditions. Flushing hole for cleaning, extra large dirt exit hole.

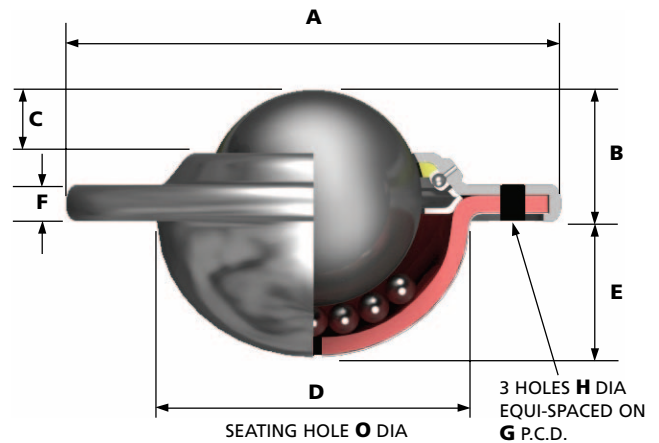

3 HOLES FOR HEAVY DUTY FIXING

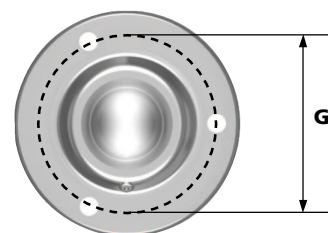

REF No.	FIXING HOLES	BALL SIZE (mm)	WEIGHT (KGS)	DIMENSIONS (mm)								
				A	B	C	D	E	F	G	H	O
3016	2	15.8	0.045	41.3	10.2	4	22.2 ±0.2	8.3	3.2	30 ±0.2	3.5	23
3000	2	19	0.087	61	10	3.2	29.1 ±0.2	12	3.2	44.5 ±0.2	5.1	30
3006	3											
3025	2	25.4	0.135	56	14.6	7.3	34.7 ±0.2	14.6	4	45.5 ±0.2	4.5	35.5
1000	2	25.4	0.175	73	14.2	6.3	37.2 ±0.2	15.8	3.5	55.6 ±0.2		38.1
1008	3											
1022	3	31.7	0.265	73.7	16.2	8	45.5 ±0.2	19.9	4.2	58.7 ±0.2	5.1	46.5
1035	2											
32742	2	31.7	0.270	73.7	16.2	8	45.5 ±0.2	19.9	4.2	58.7 ±0.2	5.1	46.5
32743	3											
2000	2	39.7	0.515	89	21.4	8.7	55.6 ±0.2	24.6	6	70 ±0.2	7	56.5
2011	3											
4001	3	50.8	1.065	120.7	28.3	14.3	75.3 ±0.2	30.2	6.3	92 ±0.2	8	76.5

MAXIMUM DYNAMIC LOADING (kg)							
TYPE 13		TYPE 14		TYPE 15		TYPE 16	
Carbon Steel Bearings, Zinc Plated Pressings		Nylon Load Bearing, Zinc Plated Pressings		Stainless Steel Bearings and Pressings		Stainless Steel Bearings, Zinc Plated Pressings	
LOAD UP	LOAD DOWN	LOAD UP	LOAD DOWN	LOAD UP	LOAD DOWN	LOAD UP	LOAD DOWN
12	6	8	4	12	6	12	6
25	10	20	10	25	10	25	10
55	25	25	10	55	25	55	25
125	55	25	10	125	55	125	55
140	60	N/A	N/A	140	60	140	60
340	100	N/A	N/A	250	100	340	100

The 32742 and 32743 ball units have 7 dirt exit holes for removal of dirt and debris and no seal

DIMENSIONS (mm)										
B	C	D	E	F	G	H	J	K	L	R
Working Height of Ball	Ball Exposure above Outer Ring	Body Diameter	Under Flange to Base	Flange Thickness	P.C.D. or Centres of Fixing Holes	Hole Diameter of Fixing Holes	Major Flange Size	Minor Flange Size	Overall Height	Radius Under Flange

1502	2	25.4	0.196	12	6	42 ±0.2	24.5	1.7	58.7 ±0.2	5.1	68.1	50	36.5	5
------	---	------	-------	----	---	---------	------	-----	-----------	-----	------	----	------	---

100	50	25	10	100	50	100	50
-----	----	----	----	-----	----	-----	----

DIMENSIONS (mm)										
A	B	C	D	E	F	G	H	O	T	
Max Diameter	Working Height of Ball	Ball Exposure above Outer Ring	Body Diameter	Under Flange to Base	Flange Thickness	P.C.D. or Centres of Fixing Holes	Hole Diameter of Fixing Holes	Seating Hole Diameter	Table Top Thickness	

1010	-	25.4	0.195	73	15.4	6.3	36.8 ±0.2	15	4.8	N/A	N/A	50	5
1030	-	31.7	0.275	73.7	17	8	44.6 ±0.2	19.5	5	N/A	N/A	50	5

55	25	25	10	55	25	55	25
125	55	25	10	125	55	125	55

DIMENSIONS (mm)									
A	B	C	D	E	F	G	H	O	
Max Diameter	Working Height of Ball	Ball Exposure above Outer Ring	Body Diameter	Under Flange to Base	Flange Thickness	P.C.D. or Centres of Fixing Holes	Hole Diameter of Fixing Holes	Seating Hole Diameter	

2002	3	39.7	0.635	94.6	21.2	6.9	62 ±0.2	27.3	6.3	76.2 ±0.2	7	63.3
------	---	------	-------	------	------	-----	---------	------	-----	-----------	---	------

225	100	N/A	N/A	225	100	225	100
-----	-----	-----	-----	-----	-----	-----	-----

To order, specify REF N° and TYPE, i.e. 3016-13.

General Tolerance unless stated ±0.3mm